

35'-11" BUMPER-TO-BUMPER

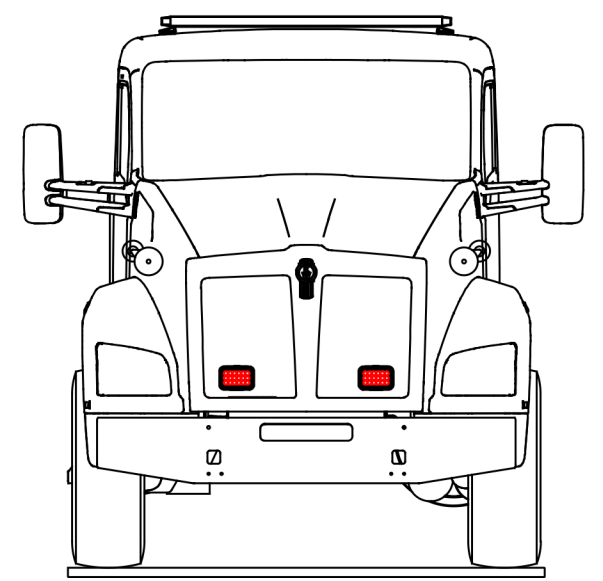

JOB NO.: FT1009
COMMERCIAL SUPER PUMPER FOAM UNIT
6,000 GPM US FIRE PUMP
2,000 GALLON FOAM TANK

	INTERIOR	OPENING
L1	61.50W X 70.25H X 15/28D	39.75W X 61.50H
L2/L3	51.00W X 37.50H X 15D	48.50W X 28.75H
L4	73.50W X 70.25H X PUMP PANEL	71.00W X 61.50H
R1	42.25W X 70.25H X 15/28D	39.75W X 61.50H
R2	42.25W X 70.25H X 15/28D	39.75W X 61.50H
R3/R4	51.00W X 37.50H X 15D	48.50W X 28.75H
R5	73.50W X 70.25H X PUMP PANEL	71.00W X 61.50H

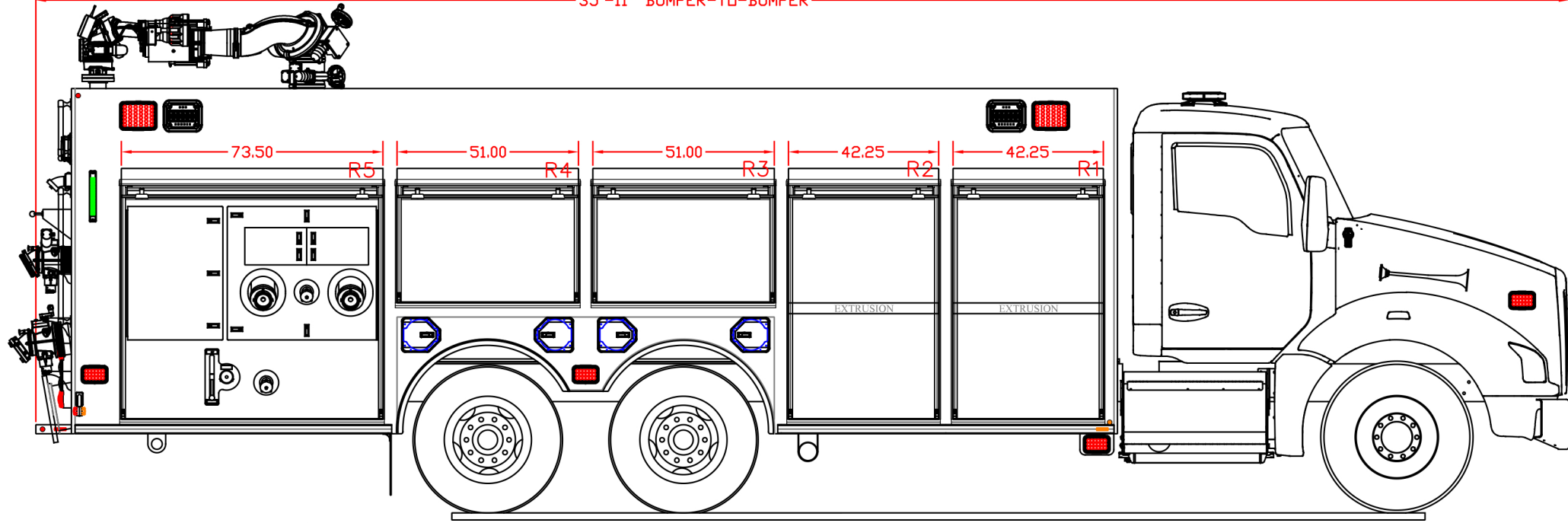
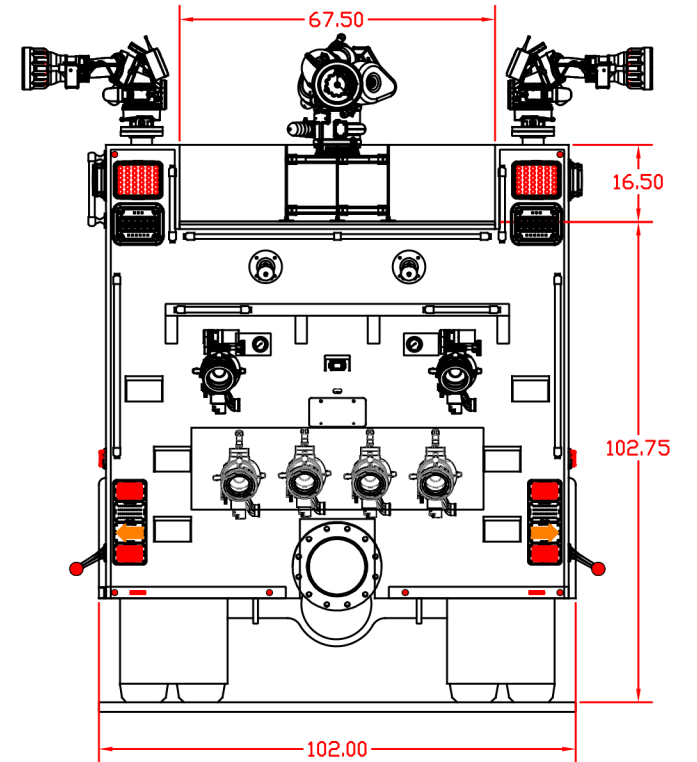
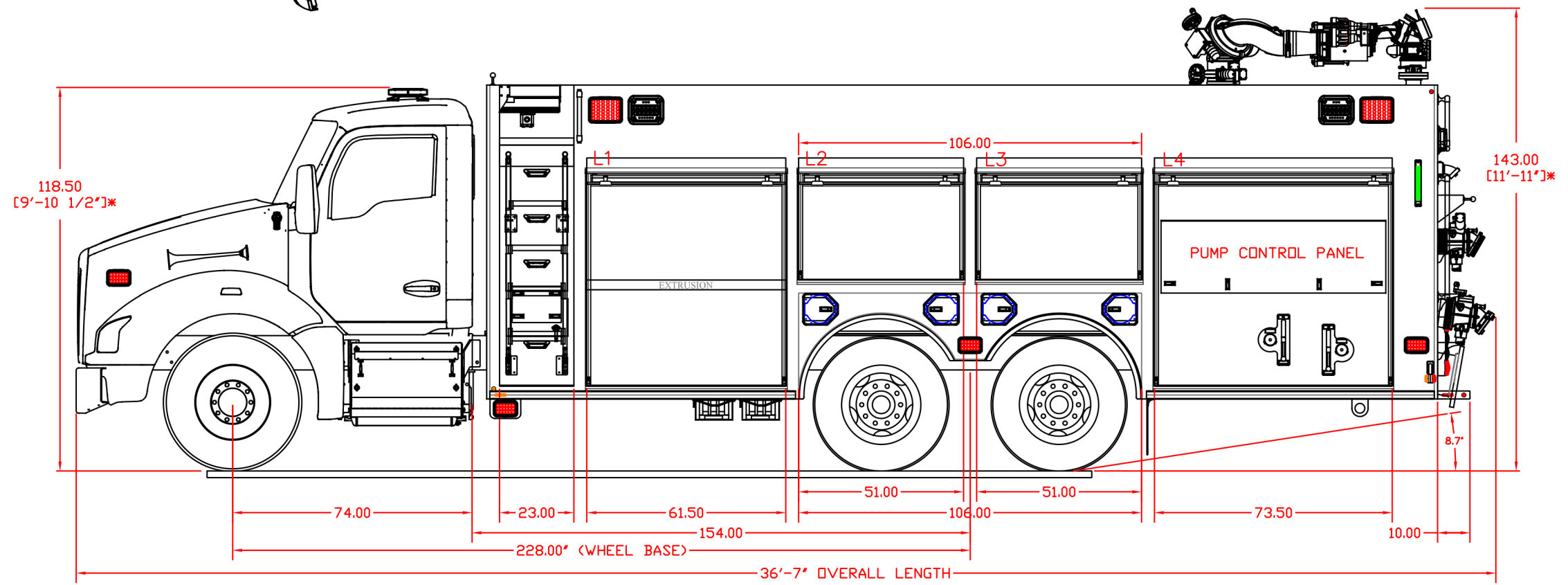
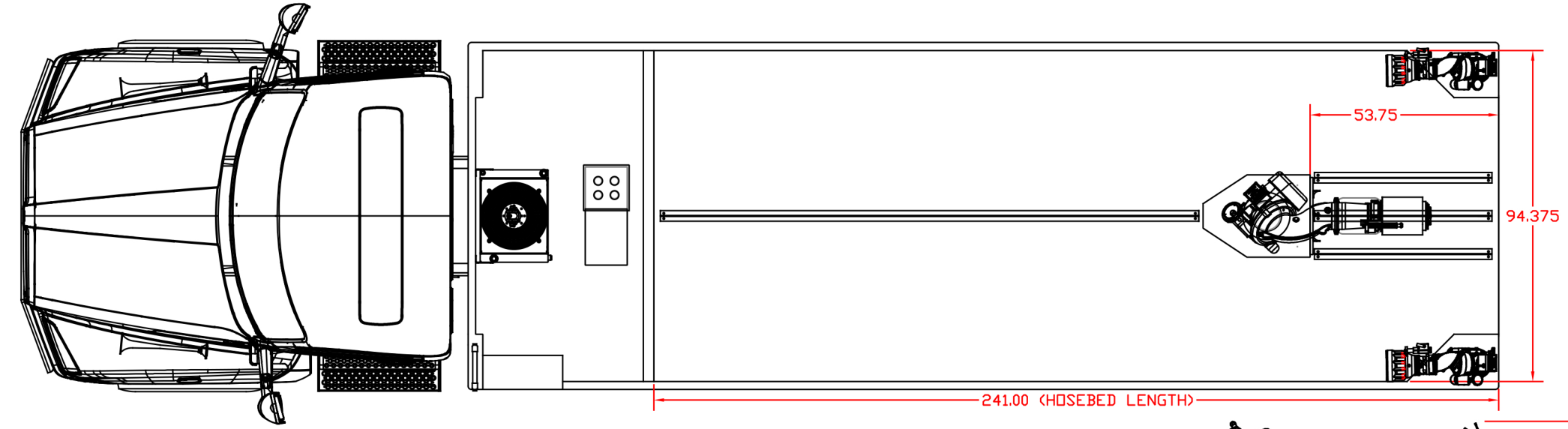

*HEIGHT COULD VARY +/- 2" BASED ON LOADING OF VEHICLE