

JOB NO.: FT1041
2,000 GPM HALE QMAX PUMP
1,000 GALLON WATER TANK
***30 GALLON FOAM CELL**
(*FOR OPTIONAL FOAM SYSTEM)

	INTERIOR	OPENING
L1	46W X 70.25H X 15/28D	44.00W X 60.875H
L2	58W X 38H X 15D	56.00W X 28.625H
L3	44W X 70.25H X 15/28D	42.00W X 60.875H
R1	46W X 70.25H X 15/28D	44.00W X 60.875H
R2	58W X 38H X 15D	56.00W X 28.625H
R3	44W X 70.25H X 15/28D	42.00W X 60.875H
B1	35W X 60.50H X 28D	33.00W X 51.125H

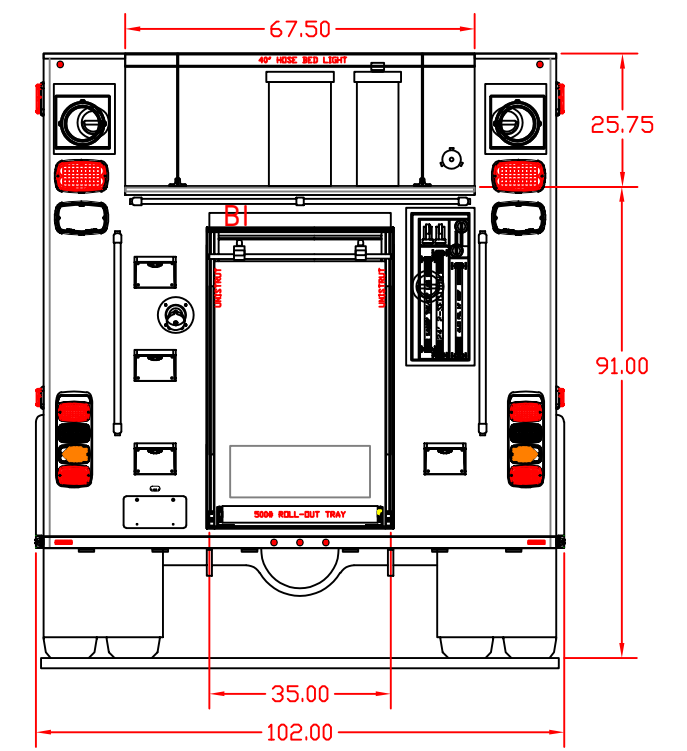
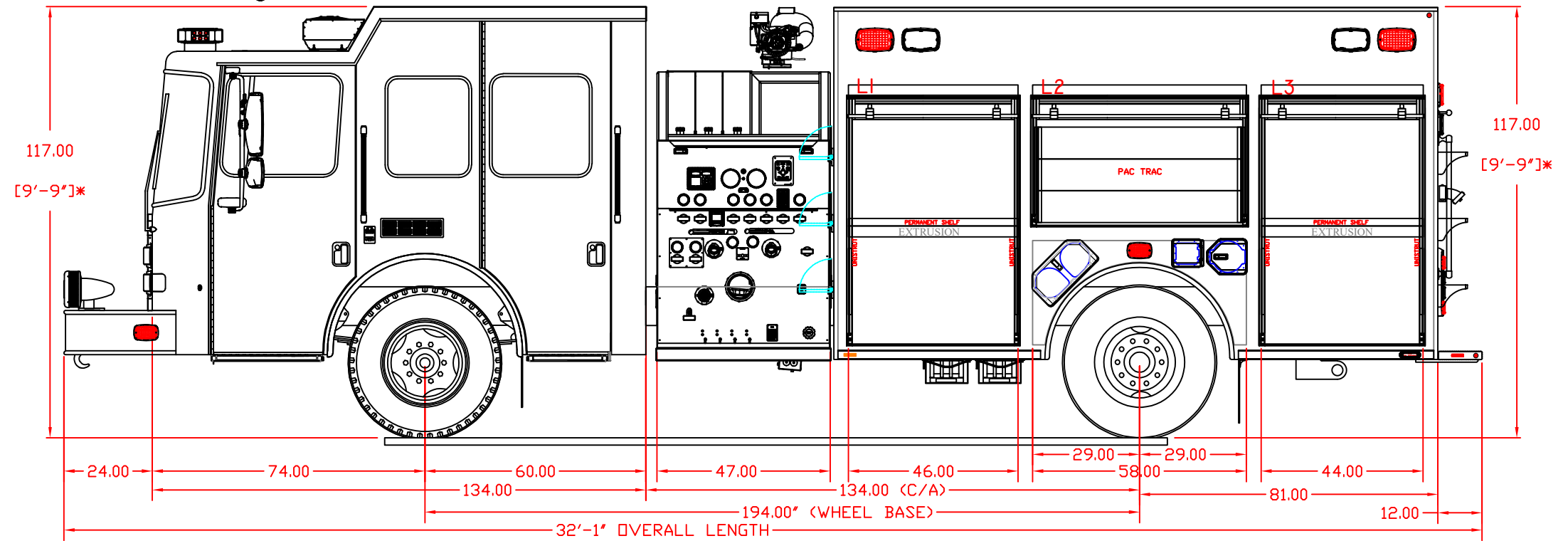
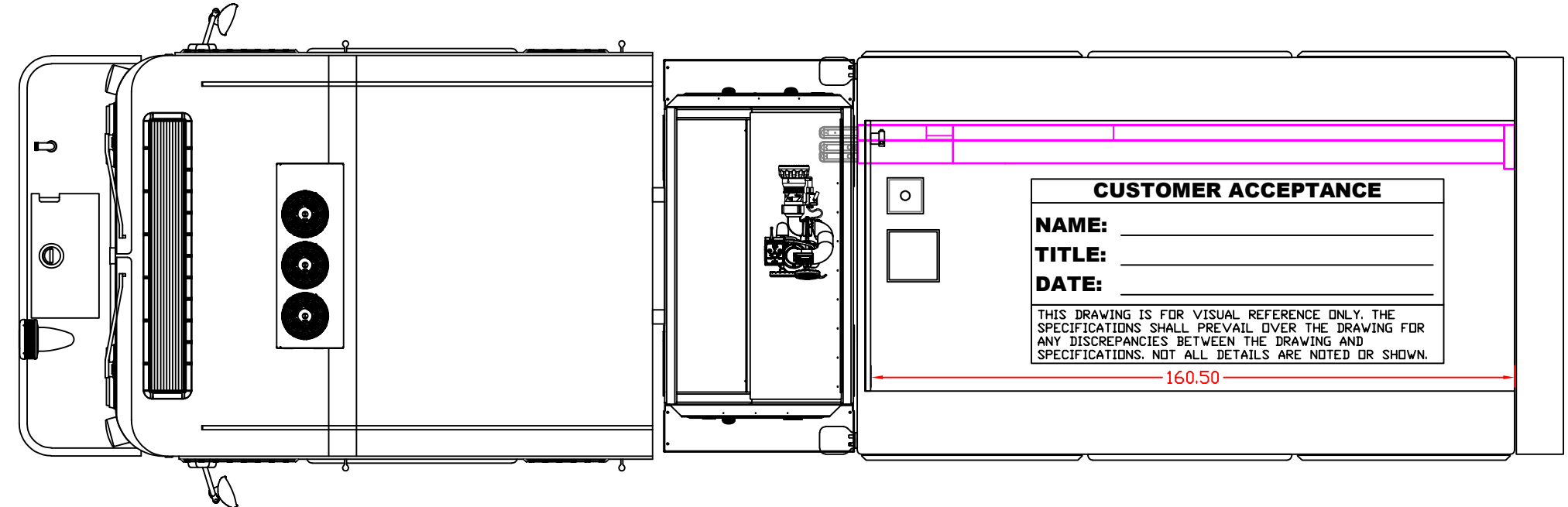

*HEIGHT COULD VARY +/- 2" BASED ON LOADING OF VEHICLE